

Cylinder - Hydraulic Main Gear Retract

11-5B, 11-5C, 11-5D, 11-18

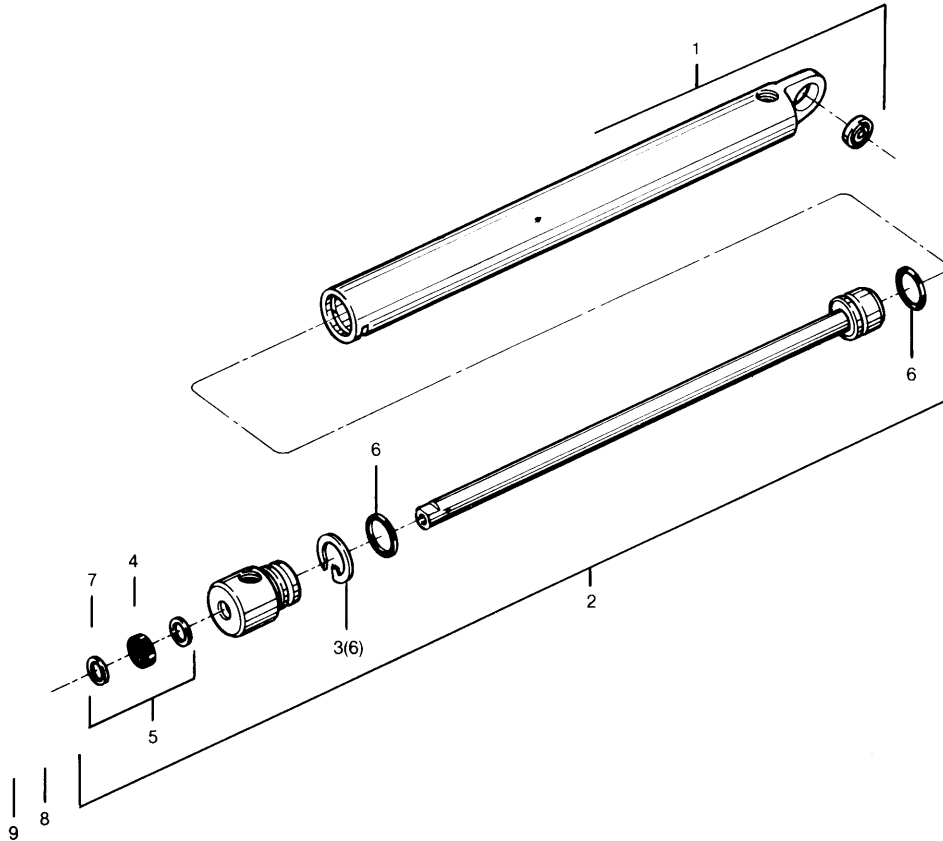

FIG.	PART NUMBER	DESCRIPTION	ASSEMBLY NUMBER	QTY. PER ASSY.			
				11-5B(1)	11-5C(2)	11-5D(3)	11-18
1	189-26	Body Assembly		1	1	1	
	189-36	Body Assembly					1
2	111-69(4)	Piston Rod & Gland Assy.		1			
	111-70(4)	Piston Rod & Gland Assy.			1	1	
	111-72(4)	Piston Rod & Gland Assy.					1
3	155-29	Retainer (6)		1	1	1	1
4	101-50110	O-Ring (MS28775-110)		1	1		
5	101-274	T-Seal (600 RS-110-04182)				1	
6	101-50113	O-Ring (MS28775-113)		2	2	2	1
7	100-20008	Back-Up Ring (MS28782-8)		1	1		
8	94-30	Nut-Jam					1
9	143-9	Clevis					1
	199-537	Seal Repair Kit		1	1		
	199-538	Seal Repair Kit				1	
	199-539	Seal Repair Kit					1

Notes:

- (1) 11-5B Cylinder also known as SFA 232-3.
- (2) 11-5C Cylinder also known as SFA 232-4.
- (3) 11-5D Cylinder also known as SFA 232-5.
- (4) Includes parts contained in Seal Repair Kits.
- (5) For design and installation specifications, contact Customer Service.
- (6) See Piper Service manual for removal and installation instructions.

July 1, 1985